

User's Manual

Bluetooth Digital External Caliper Gauge

Type : SSGM Series

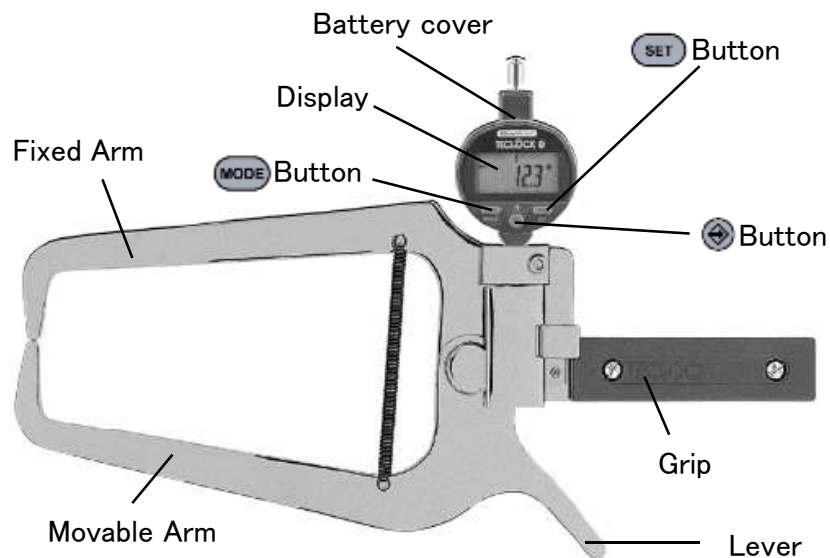

Parts	Features
Battery Cover	for exchange the Battery(CR2032)
Display	Display Measuring value, Setting mode, etc.
MODE Button	Basic function by short press, Advanced function by long press
SET Button	Change each mode, digit, etc.
Button	Send button on Measuring, Enter button on setting
Lever	Lifting lever for putting in the work
Fixed Arm	Flame for measuring base
Movable Arm	Lifting flame on putting in the work
Grip	Grip

*1) Refer to Indicator manual for detail operation.

*2) Refer to Chapter 6 about Probe shape.

Descriptions

SSGM-1

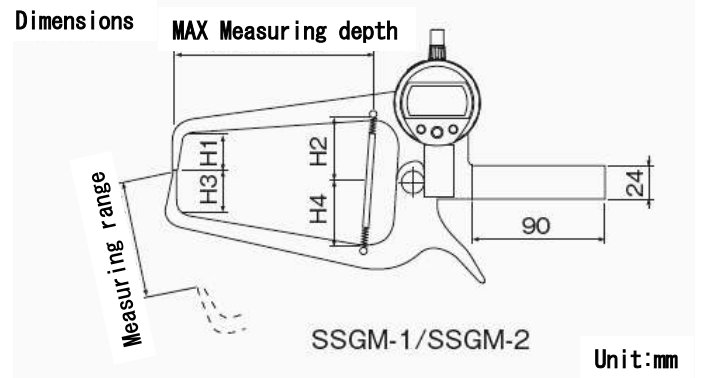
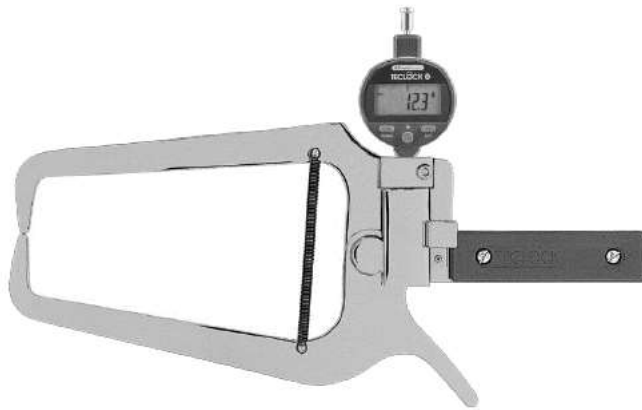

SSGM-2

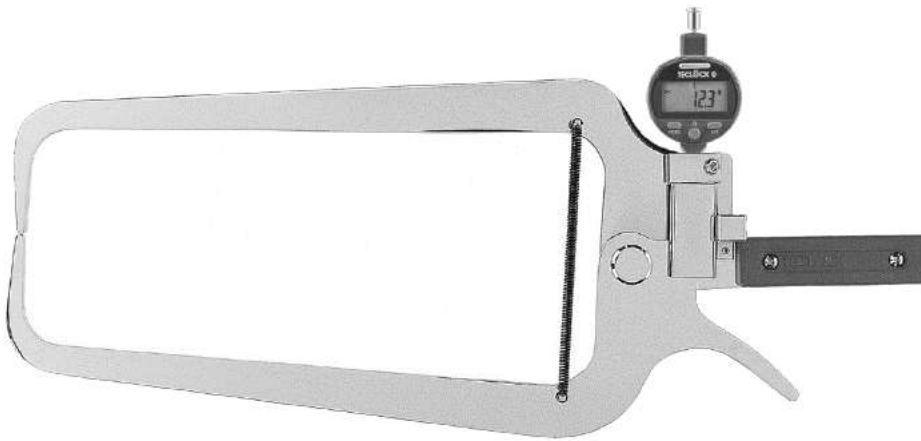

Dimensions

Type	H ₁	H ₂	H ₃	H ₄
SSGM-1	25	40	25	40
SSGM-2	50	60	50	60

Unit:mm

SSGM-8

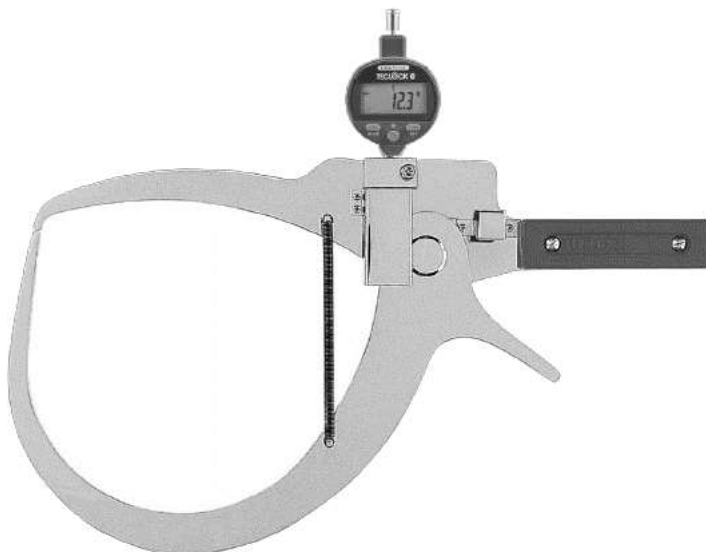

Dimensions

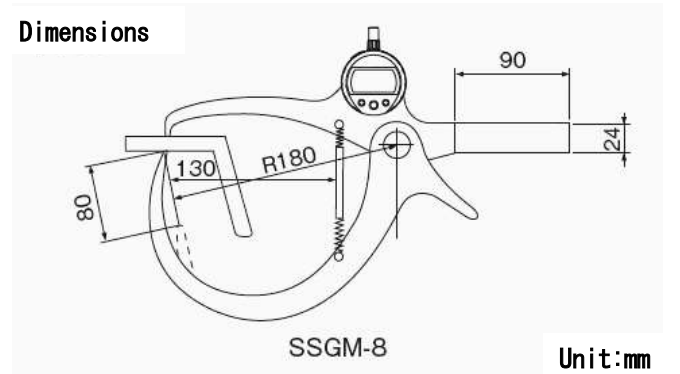

1. Power on/off operation

(1) Power on Press any button, then Power on.

(2) Power off

① Long press  button(2 sec. or more), then it is standby and display is disappeared.

② Long press  button(4 sec. or more), then 「off」displayed and Power off.

※)In the case of no using for a long time, do ② operation.

2. Preparation for Measuring



(1) Setting for Bluetooth

① Long press  button, then Advanced mode. (「Unit」displayed)

② Short press  button 5 times, then 「bt CFG」displayed.(Bluetooth setting mode)

③ Short press  button any times, then select 「HID」 or 「PAIr」 and press  button.

④ Short press  button any times, then 「bt」displayed.(Bluetooth setting mode)









⑤ Short press  button, then select 「on」 and press  button.(Bluetooth on mode)

⑥ Short press  button any times, then 「bt」displayed.(Bluetooth setting mode)

⑦ Short press  button, then 「rESEt」displayed and press  button.(Bluetooth Reset)

⑧ Pair connection with PC.

⑨ Display on Bluetooth mode

Display status	Operating mode
 off	Bluetooth disconnected
 blinkinn	Bluetooth advertising
 on	Bluetooth connected
	reset : clear pairing information
	MAC : display the MAC address
	Simple : profile without pairing
	Pair : paired and secured profile
	HID : virtual keyboard

Pairing mode	Instrument name on PC display
	Mini Indicator
Pair	SY303
HID	S Dial Mini HID

3. Measuring

(1) Setting zero point

① Hold this Moving arm in standing position.

② Short press  button, 「Zero」displayed and reset.

(2) Setting MIN mode

① Short press  button 2 times, then 「Mode」displayed.

② Short press  button any times, then 「Min」displayed.

③ Press  button, then MIN mode is fixed.

(3) Measuring

① Place a work between Arms by Lever.

② Short press  button, then MIN value is reset.

③ The MIN value is fixed by holding a work with Arms and Shaking Arms to left and right (or up and down).

④ Press  button, then measuring data(MIN value) is sent to PC.

4. Maintenance

Carefully dry all mechanical parts of the instrument after contact with liquids to ensure proper operation and avoid corrosion.

Don't use aggressive products (alcohol, trichloroethylene or others) to clean plastic parts.

Don't expose the instrument to direct sunlight, heat or humidity.

5. Installing and replacing the battery





Mini Indicator (SSI-150S)



6. Specifications

Type	SSGM-1	SSGM-2	SSGM-8
Resolution(mm)	0.1		
Measuring range(mm)	0-90	0-90	0-80
Indication error(mm)	±0.1		
Measuring force (N)	5 or less		
MAX Measuring depth(mm)	125	250	130
Weight(g)	465	735	485
Built-in Indicator	SSI-150S		
Working temperature(°C)	5~40		
Storage temperature(°C)	-10~60		
IP protection	IP67		
Battery life	About 6 months (under general using)		
Battery	CR2032		

7. Certification

contains bluetooth module	ISP091201D
Region	Certification
USA	FCC ID : 2AAQS-ISP091201
Canada	IC : 11306A-ISP091201
Brazil	Anatel : 0516-14-4534
Korea South	 MSIP-CRM-iNs-ISP091201
Mexico	IFT : RCPSYIS14-0655
Japan	 R001-A06167
Taiwan	 CCAH18LP2040T6
EU	
India	WPC : ETA-1003/2-17-/RLO(WR)

CERTIFICATE OF CALIBRATION

We hereby certify that this product has been calibrated and found to be in accordance with the applicable NATIONAL STANDARDS and TECLOCK STANDARDS, Equipment used in this calibration has traceable accuracy to the NATIONAL LENGTH and FORCE STANDARD.



Notice for use

Be sure to conduct a routine check for this product according to the purpose of use before use. This product is precision instrument, periodically considering frequency of use, environmental conditions and method of use.

It is not guaranteed for the performance of this product, which has been repaired or disassembled by other than TECLOCK.

For appearance and other design improvement, this products subject to change without advance notice.

TECLOCK Corporation

TECLOCK SmartSolutions Corporation

<http://www.teclock.co.jp>

HEAD OFFICE

2-10-3 MARUTA-CHO, OKAYA-SHI, NAGANO-KEN 394-0042

PHONE:81-266-22-4912, FACSIMILE:81-266-22-4914

E-mail:teclock@teclock.co.jp