

11 Stand

Stands which can make precision measurement of work piece by mounting Dial indicator or Digital indicator.

These are stands which can make precision measurement of work piece by mounting Dial Indicator or Digital Indicator. As to natural granite (micro-granite) base, its organization is fine particle and work piece slides smoothly without ringing. Stable and high flatness accuracy within 0.001mm / 200mm square is also characteristics. Please select referring to size of base or fine adjustment device from various lineup.



It is measured a work piece by mounting dial indicator on a stand.



Granite Comparator Stand ----- 132-133
Upright Stand ----- 133

Holder Stand for Thickness Gauge ----- 134
Magnetic Base ----- 134

Granite Comparator Stand

- Natural micro-granite is used for all granite comparator stands.
- Flatness accuracy : within 0.001mm / 200mm square.
- Sliding smoothly and objects to be measured are not damaged. It is superior for anti-abrasion.
- The rigid granite base is free from burrs and pileups.
- It is easy for maintenance as base never suffers from rust.



USG-10

·Base size
100x150x50 mm



USG-24

·Base size
150x150x50 mm



USG-29

·Base size
150x200x50 mm



USG-30

·Base size
150x200x50 mm

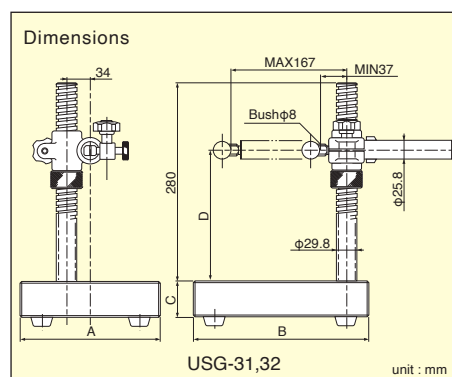
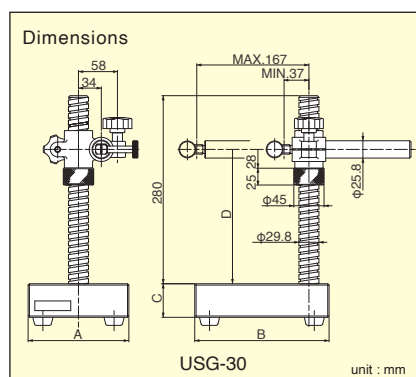
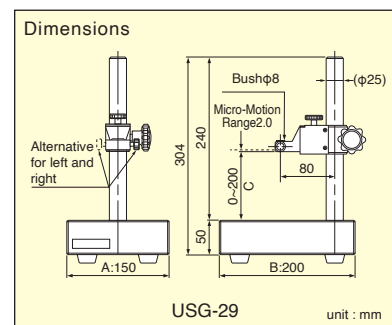
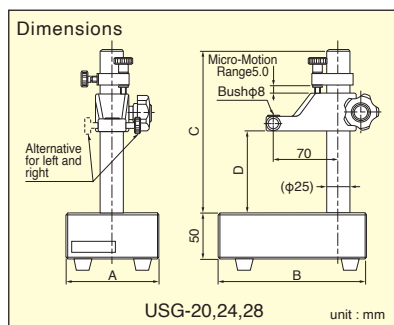
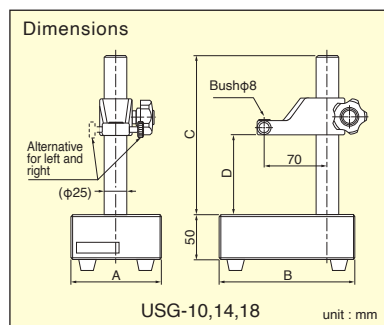

Specifications

Model	Type	Base size(AxB)(mm)	Height of Column(C)(mm)	Movable Range(D)(mm)	Weight (kg)	Suggested List Price
USG-10	Standard	100×150	175	0~130	3.5	44,330 JPY
USG-14	Standard	150×150	175	0~130	4.9	47,410 JPY
USG-18	Standard	150×200	240	0~200	5.8	50,380 JPY
USG-20	Fine Adjustment	100×150	175	0~115	3.5	51,040 JPY
USG-24	Fine Adjustment	150×150	175	0~115	4.9	54,450 JPY
USG-28	Fine Adjustment	150×200	240	0~180	5.8	57,970 JPY
USG-29	Precision Fine Adjustment	150×200	240	0~200	6.0	69,630 JPY

Model	Type	Base size(AxBxC)(mm)	Movable Range (D)(mm)	Bush φE (mm)	Weight (kg)	Suggested List Price
USG-30	Square Screw, Arm Slide	150×200×50	53~250	φ8	7.3	87,230 JPY
USG-31	Square Screw, Arm Slide	200×250×50	53~250	φ8	10.5	91,520 JPY
USG-32	Square Screw, Arm Slide	250×250×50	53~250	φ8	12.5	94,600 JPY

For USG30~32, depending on the measuring device in use, the probe may not contact to the base surface since the effective movable range is 53mm or more. Use an extension rod or the like to extend.
 Other combinations of Base and Column than the above chart are also possible.
 The Base is possible to be made up to 500×500mm according to the requested size.

Upright Stand

- This can be easily used by only mounting Dial Indicator for comparison measurement.
- This small stand is suitable for measuring small parts etc.

US-16B

- Specimen table size 80×80mm
- Standard Type

- Precision Grinding Cast Iron base



US-22B

- Specimen table size 80×80mm
- With fine adjustment device

- Precision Grinding Cast Iron base



US-25

- Specimen table size φ60mm Ceramic
- With fine adjustment device

- Precision Grinding Cast Iron base

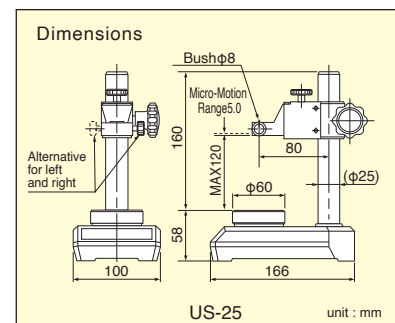
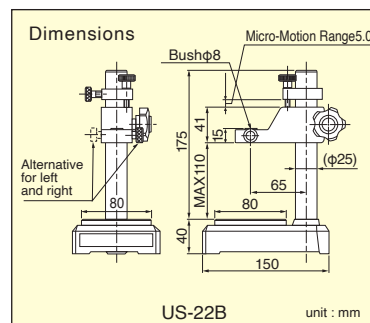
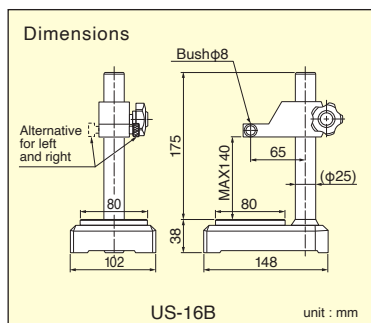

Specifications

Model	Type	Specimen Table Size(mm)	Movable Range(mm)	Weight(kg)	Suggested List Price
US-16B	Standard Type	80×80	0~140	3.4	27,280 JPY
US-22B	With Micro-Motion Device	80×80	0~110	3.5	33,660 JPY
US-25	Parallel Spring Type Precision Micro-Motion Device	φ60	0~120	3.9	77,880 JPY

Holder Stand for Thickness Gauge



FM-18

- Clamping angle can be adjusted.
- Thickness Gauge is optional item.

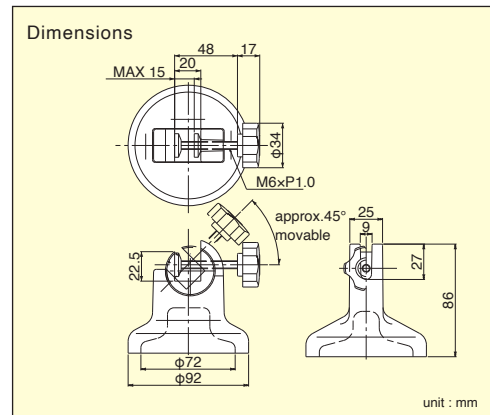

Specifications

Model	Size (mm)	Weight(g)	Suggested List Price
FM-18	base $\phi 92$, height 86	850	11,660 JPY

Magnetic Base

- Magnetic base can hold a measuring device such as dial indicator.
- Adaptor (Internal diameter $\phi 6\text{mm}$) is supplied for holding test indicators on model : MB-1040 and MB-1050.
- MB-1040 / 1050 can also be fixed with dovetail of auto-clutch lever test.
- Dial indicator is mounted to MB-B with lug back and test indicator is clamped with stem (It can not be clamped with dovetail).
- MB-1040 / 1050 can not be clamped with dovetail.



MB-1040

MB-1050

MB-B



Example Magnetic Base with Test Indicator. Dial indicator is also applied.

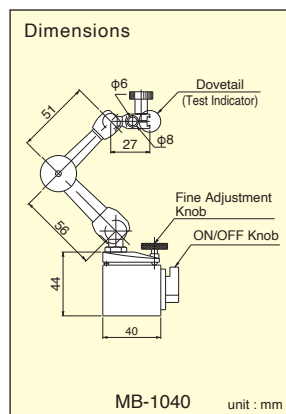

MB-1040 unit : mm

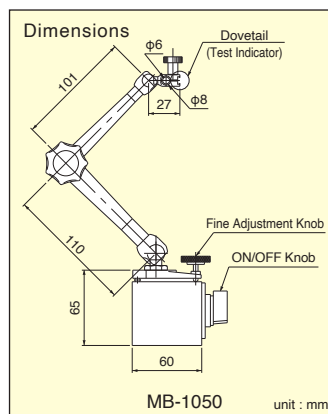

MB-1050 unit : mm

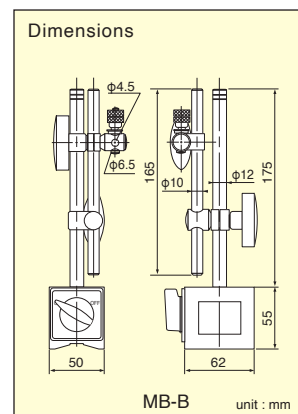

MB-B unit : mm

Specifications

Model	Type	Holding Power(N)	Mount Hole Diameter(mm)	Weight(kg)	Suggested List Price
MB-1040	One-touch, fine adjustment, small	320	6.0/8.0	0.5	21,560 JPY
MB-1050	One-touch, fine adjustment	800	6.0/8.0	1.4	26,070 JPY
MB-B	Standard	800	6.0/8.0	1.5	7,150 JPY